

In-the-spectacle-lens telescopic device

Eli Peli

Harvard Medical School
Schepens Eye Research Institute
20 Staniford Street
Boston Massachusetts 02114
E-mail: eli.peli@schepens.harvard.edu

Fernando Vargas-Martín

Harvard Medical School
Schepens Eye Research Institute
20 Staniford Street
Boston Massachusetts 02114
and
Universidad de Murcia
Departamento de Física
Edificio C, Campus de Espinardo
Murcia, 30100 Spain

Abstract. Spectacle-mounted telescopic systems are prescribed for individuals with visual impairments. Bioptic telescopes are typically mounted toward the top of the spectacle lens (or above the frame) with the telescope eyepiece positioned above the wearer's pupil. This allows the wearer to use up and down head tilt movements to quickly alternate between the unmagnified wide view (through the carrier lens) and the magnified narrow field of view (available through the eyepiece). Rejection of this visual aid has been attributed mainly to its appearance and to the limited field of view through the smaller Galilean designs. We designed a wide-field Keplerian telescope that is built completely within the spectacle lens. The design uses embedded mirrors inside the carrier lens for optical pathway folding, and conventional lenses or curved mirrors for magnification power. The short height of the ocular, its position, and a small tilt of the ocular mirror enable the wearer to simultaneously view the magnified field above the unmagnified view of the uninterrupted horizontal field. These features improve the cosmetics and utility of the device. The in-the-lens design allows the telescope to be mass produced as a commodity ophthalmic lens blank that can be surfaced to include the wearer's spectacle prescription. © 2008 Society of Photo-Optical Instrumentation Engineers. [DOI: 10.1117/1.2940360]

Keywords: visual multiplexing; bioptic telescope; optical visual aid; low vision; macular degeneration; vision rehabilitation; driving aids.

Paper 07332R received Aug. 16, 2007; revised manuscript received Jan. 5, 2008; accepted for publication Jan. 7, 2008; published online Jun. 24, 2008.

1 Background

Magnification is useful for individuals who suffer from loss of resolution or contrast sensitivity, due to defects in the optics of the eye or retina. Damage to the fovea (the central part of the retina) is common in age-related macular degeneration (AMD) and many other diseases. This impairment dramatically affects an individual's ability to read, recognize faces, and perform other fine discrimination tasks. As the population ages, the number of people affected by this and other eye diseases causing similar impairments is expected to grow rapidly.

It is possible to provide sufficient magnification for reading and other tasks performed within arm's length using a range of devices, including high-power reading glasses, hand-and stand-optical magnifiers (using standard lenses, combined standard and binary optics¹), fiber optics tapers,² and electronic magnifiers that use a camera and a display.³ A variety of telescopic devices are used for magnification of distant objects including hand-held, head-mounted, and spectacle-mounted telescopes in both Galilean and Keplerian designs.⁴ For intermediate distances, telescopic devices with manual and electronic autofocus⁵ mechanisms have been implemented.

The most successful telescopic devices to assist individuals with low vision (vision impairment) are bioptic telescopes.

Bioptic telescopes are mounted through the spectacle lens (the carrier lens). The telescope's eyepiece (ocular lens) is usually positioned above the pupil of the wearer. The telescope is tilted up by about 10 deg (Fig. 1). This allows the wearer to look under the telescope eyepiece using their unaided vision through the carrier lens most of the time. When the wearer notes an object of interest through the carrier lens that is not resolvable, a slight head tilt can bring the object into view through the telescope, providing the needed magnification. This mode of operation (providing magnification on demand) has been termed temporal multiplexing.⁶

Bioptic telescopes are permitted as driving visual aids for people with low vision in 36 states in the United States.⁷ When driving (a relatively demanding task), wearers report looking through the telescope only about 5% of the time.⁸ In other tasks, the telescope may be used even less frequently.

Through the first part of the 20th century many patents were filed disclosing bioptic telescopes for the treatment of low vision in the United States and Europe.⁹⁻¹¹ However, the devices were made popular and effective through the efforts of Feinbloom, who was the first to promote them as a driving aid.¹²

Early bioptics were fixed-focus Galilean designs that facilitated small and light-weight devices. The emphasis on small, compact designs resulted in narrow fields of view (e.g., about 9 deg in a 3× telescope^{13,14}) and generally provided relatively dim images. Eventually, Keplerian-based bioptic

Address all correspondence to Eli Peli, Schepens Eye Research Institute, Harvard Medical School, 20 Staniford St., Boston, MA 02114; Tel: 1-617-912-2597; Fax: 1-617-912-0112; E-mail: eli.peli@schepens.harvard.edu



Fig. 1 A monocular Keplerian bioptic telescope. (a) Most of the time the wearer views through the carrier lens without any effect of the telescope. (b) With a slight downward tilt of the head, the telescope is brought into the line of sight, enabling a magnified view of the object of interest. The telescope shown is the 3× mini focusable Keplerian bioptic manufactured by Ocutech, Incorporated (Chapel Hill, North Carolina).

telescopes were developed that provided brighter images and wider field of view (FOV) (e.g., 13 deg in a 3× telescope¹³). The Keplerian telescopes were larger and heavier due to the inherently longer optical path and the need for image-erecting components.

Although bioptic telescopes can be effectively used in a variety of settings,¹⁵ many visually impaired people reject them.¹⁶ The obvious and unsightly appearance of these devices has been identified as one major reason for the reluctance of people with vision impairments to use them. Also, the position of the bioptic telescope in the carrier lens causes it to interfere with eye contact that is crucial for social interactions. Various approaches were taken in attempts to improve the cosmetic appearance of bioptic telescopes, including the use of very small Galilean telescopes,¹³ small (mostly behind-the-spectacle-lens) Keplerian telescopes,^{17,18} and horizontal telescopes folded above the spectacle lenses.¹⁹ While each of these devices attempts to address the cosmetic issues hindering the bioptic telescope, they remain obtrusive, and many patients who could benefit from their use continue to reject them. In addition, attempts at miniaturization^{20,21} invariably result in optical compromises, including reductions in FOV, image brightness, or both.

A somewhat less noticeable telescope can be created by combining a high negative power contact lens²² or surgically implanted intraocular lens (IOL)²³ with a high positive power spectacle lens. Such telescopes have limited magnification, though 3× is possible. While they may have a slightly wider FOV than spectacle-mounted telescopes, they severely restrict eye scanning ability by stabilizing the image on the retina.^{24,25} Because the system's nodal point is close to the eye's center of rotation, eye movements do not result in retinal image movements.²⁶ Therefore, all scanning of the image has to be carried out using head movements. Additionally, the high power spectacle lens magnifies and distorts the wearer's eyes, and thus interferes with social eye contact. Patients rejected the cosmetics of the contact lens-spectacle system due to the unsightly appearance of the high power spectacle lens.²⁷ Furthermore, we believe that the image stabilization and the full-time field restriction imposed by these systems (when used binocularly, as they were designed) may also have contributed to the rejection of these devices. A bifocal intraocular implantable lens (IOL) was developed to be used either with a high

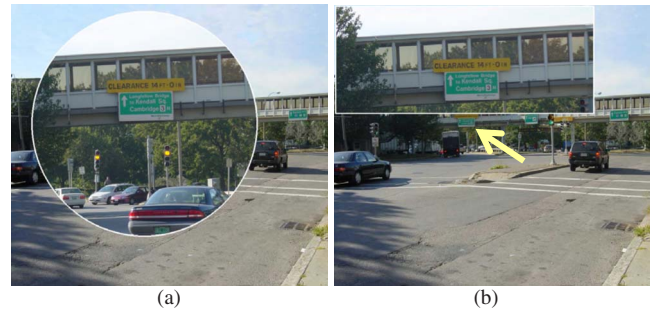

Fig. 2 A simulated view of a road sign viewed through a 3× telescope. (a) The view through a conventional bioptic. The magnified image on the retina blocks the view of much of the intersection, creating a ring scotoma (blind area). (b) The rectangular field of view through the in-the-lens telescope. The magnified image is shifted up, blocking part of the view of the overhead pedestrian bridge, but leaves the intersection in full view. Note the nonmagnified view of the road sign seen under the magnified view. The white line surrounding the magnified image is only added to make the illustration clearer.

power spectacle lens for magnification, or without it for a nonmagnified view.²⁸ Despite reported success in the optical performance of these devices,²⁸ the large size and poor cosmetics of the doublet spectacle lens that was used is believed to be the reason for the rejection of such systems by wearers. Here too, the retinal image stabilization prevented eye scanning. Using a small high-power inset lens in a normal-looking carrier lens in combination with the bifocal IOL²⁹ might overcome both the cosmetics and image-scanning limitations of this approach. A fully implanted intraocular telescope is now available that offers normal-looking spectacles and eyes, but requires a surgical procedure.^{30,31} The telescope is implanted in one eye, leaving the second eye to provide a wide field of vision for mobility tasks. In comparison with spectacle-mounted telescopes, the intraocular telescope provides dimmer retinal images, and may interfere with ocular examination and treatment. This miniature telescope also has a limited FOV, though not as limited as comparable spectacle-mounted bioptics, and it permits natural eye scanning.²⁵ The implantable devices have a fixed level of magnification, preventing a change in power that may be desirable with progression of the vision impairment.

While patients are concerned with the cosmetics of the device, low vision professionals who object to the use of the bioptic telescope while driving frequently raise the presence of a ring-shaped scotoma (blind area) around the magnified image [Fig. 2(a)] as a cause for concern.^{32,33} The blind area is a direct result of the magnification of the telescope that spreads the image over a larger retinal area, and consequently prevents that retinal area from imaging the surrounding scene.

The ring scotoma problem may be alleviated in two ways. In most cases the bioptic is fitted over one eye (monocularly). It has been argued that the other eye, if functional, can continue to monitor the area corresponding to the ring scotoma and thus avoid this potential difficulty.^{12,34} We have termed that situation biocular multiplexing.⁶ A second way of eliminating the ring scotoma may be applied to both monocular and binocular telescopes. When looking through the bioptic telescope, the wearer can simultaneously view the magnified image of an object together with the unmagnified image of the

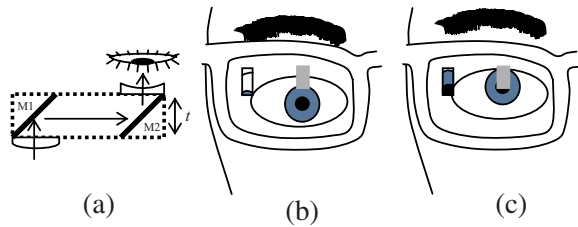

Fig. 3 (a) A basic schematic design of the in-the-lens telescope with a spectacle lens of thickness t , seen from above. For the Galilean design, a positive objective lens and a negative ocular lens are laminated to the carrier lens. Two mirrors serve to periscopically pass the image from the objective to the ocular. (b) An illustration of the in-the-lens telescope when the wearer looks through the carrier lens. (c) The same lens following a head tilt that brings the telescope in front of the pupil. Note the thin and tall shape of the telescopic mirrors due to the limitation imposed by the carrier lens thickness on the width of the mirrors.

rest of the scene, except for the ring scotoma [Fig. 2(a)]. With a small FOV, a telescope that is misaligned with the eye's optical axis can present a magnified image of an object immediately above the view of the same object through the carrier lens [Fig. 2(b)]. This method of dealing with the ring scotoma of the bioptic telescope was termed "Simulvision" and was described with the introduction of the bilevel telemicroscopic apparatus (BITA) micro-Galilean bioptic telescope.³⁵ Simulvision is an example of spatial multiplexing by shifting.⁶

In this work, we describe a low vision bioptic telescope that overcomes many of the limitations of previous designs by building the telescope into the spectacle lens.³⁶ This in-the-lens design can provide a relatively wide FOV, high magnification, and a bright image while also improving the cosmetics such that the device does not appear too different from other eyewear. We also show that the new design lends itself to spatial multiplexing by shifting, allowing a wide (unmagnified) FOV.

2 Optical Designs

The principal novelty of the in-the-lens telescope is that the optical elements composing a terrestrial telescope are embedded within the carrier spectacle lens. This requires the optical path to be folded so that it is mostly orthogonal to the visual axis of the spectacles, and light is transmitted through the carrier lens body. We describe a series of designs and implementations next.

2.1 Periscopic Galilean with Laminated Lenses

The basic Galilean telescope folded into the lens is shown schematically in Fig. 3. A plane carrier lens of thickness t is shown in a view from above as a rectangle. A positive lens serving as the objective, and a negative lens of higher power serving as the ocular, are shown laminated to the carrier lens. A pair of plane mirrors serves as a periscope to move the image from the objective to the ocular across the carrier lens.

The most important design parameter for a bioptic telescope is the magnification. Bioptic telescopes range in magnification from $1.5\times$ to $8\times$, with $3\times$ to $4\times$ used most commonly. The angular magnification M of an afocal Galilean

telescope, as shown in Fig. 3, is determined by the ratio of the object focal length of the objective lens f_{ob} (negative in this case) to the image focal length of the ocular lens f'_{oc} (also negative, since the ocular is divergent):

$$M = \frac{f_{ob}}{f'_{oc}}. \quad (1)$$

In the case of a Galilean telescope M is positive, meaning the final image is erect (not inverted).

The afocal condition is achieved when the distance between objective and ocular lenses, called tube length L , is equal to the difference of the focal lengths of both lenses. In this embedded design, light travels through the carrier lens of refractive index n . Under the thin-lens approximation, it is generally derived as:

$$L = f'_{ob} - f_{oc} = -nf_{ob} + nf'_{oc} = n(1 - M)f'_{oc}. \quad (2)$$

Attending to the sign of focal lengths in the case of the Galilean telescope, it results as:

$$L = n(M - 1)|f'_{oc}|. \quad (3)$$

The second most important parameter for a bioptic telescope is the field of view (FOV). Either the objective or the ocular may serve as the limiting aperture in a Galilean telescope. The FOV, on the retina of the wearer, is determined by either the angle spanned at the pupil by the ocular lens or the angle spanned by the image of the objective as seen through the ocular; the smaller of these two angles is the FOV. In the design of the Galilean telescope shown in Fig. 3(a), the carrier lens thickness limits the periscopic mirrors' width but not their height. Since we would like to keep the carrier lens as thin as practical for cosmetic and weight considerations, the field of such a telescope is likely to be taller than it is wide [Fig. 3(b)]. This is less than optimal, as the width of the FOV is considered more important for bioptics than the height. In addition, the exit pupil, the image of the objective formed by the ocular, is smaller than the objective itself, since the lateral magnification is $1/M$.

The second factor affecting the FOV is the distance between the field-limiting aperture and the eye's pupil. Since the device is meant to be embedded in a spectacle lens, the distance from the last optical surface to the eye should be as similar as possible to that of conventional spectacle ophthalmic lenses. This vertex distance is usually 12 to 14 mm.³⁷ In the case of the Galilean design, the exit pupil of the telescope lies within the telescope. Generally, the exit pupil acts as a field-limiting aperture and, since the eye can never be placed in the same plane, it limits the FOV and also causes vignetting by reducing the light reaching the pupil from eccentric objects.

2.2 Keplerian Design with Laminated Lenses

A Keplerian configuration for a bioptic telescope has a number of advantages over the Galilean design, as described later. The main disadvantages of a Keplerian bioptic telescope are the larger dimension of the device (for the same magnification and objective lens power) and the need for an optical erecting element that adds weight and other complications. However,

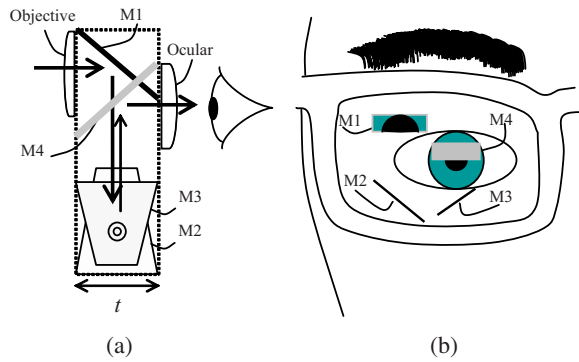

Fig. 4 (a) Side view schematic of the Keplerian design in-the-lens telescope with laminated lenses and four flat erecting mirrors. (b) Front view illustration of the Keplerian design telescope that emphasizes the wide but short configuration of the mirrors and the corresponding FOV. In this design, the carrier lens thickness limits the height but not the width of the objective and ocular mirrors.

both limitations are easily overcome with the proposed in-the-lens design. Figure 4 shows side and front view schematic illustrations of a Keplerian in-the-lens telescope. The spectacle carrier lens (dotted line rectangle) has a thickness t . The ocular and objective lenses are laminated to the carrier lens surfaces. Arrows show the direction light travels across the four embedded erecting mirrors arranged in a configuration similar to the reflections obtained in Abbé's version of the Porro prisms³⁸ (also called second-kind Porro prisms). Following a head tilt to align the telescope with the eye, the ocular and $M4$ are placed in front of the wearer's eye [as shown in Fig. 4(b)]. At other times, the wearer can view through the carrier lens, under mirror $M4$, benefiting from an unimpeded FOV.

The same computations [Eqs. (1) and (2)] apply to a Keplerian telescope with the only difference being the sign of the ocular focal length (positive), resulting in the tube length being equal to the sum of the focal lengths of both lenses

$$L = f'_{ob} - f_{oc} = n(1 + |M|)f'_{oc}. \quad (4)$$

Thus, a longer optical path is required for a Keplerian design. This additional length is not difficult to achieve, as the Keplerian design needs erecting mirrors, which naturally increases the optical path through the carrier lens.

The orientation of the objective and ocular mirrors ($M1$ and $M2$) in the Keplerian design is such that their height is limited by the carrier lens thickness but not their width (horizontal dimension). The FOV of a Keplerian telescope is limited only by the size of the ocular lens. Thus the Keplerian design in-the-lens telescope has an added advantage that the width of the FOV may be large, even with a fairly thin carrier lens. Only the height of the FOV is limited by the thickness of the carrier.

With the Keplerian design, the eye relief is positive and the exit pupil is outside the telescope, allowing the eye pupil to be conjugated with the exit pupil. Therefore, the field limiting aperture is now the ocular. This is better than the Galilean design in two ways. First, the distance from the aperture to the eye is reduced (increasing the angular span of the field), and

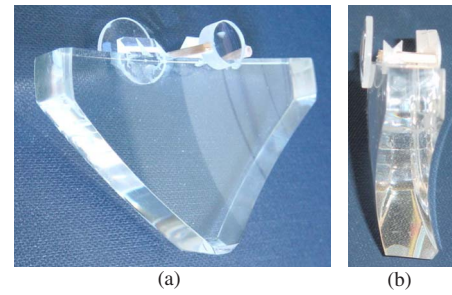

Fig. 5 (a) A back view and (b) side view of the crude prototype of the Keplerian design in-the-lens telescope illustrated in Fig. 4. The telescope was constructed from an ophthalmic lens-blank cut to provide the erecting mirrors through total internal reflection. Off-the-shelf ocular and objective lenses provided the magnification, and small right-angle prisms served as the periscopic mirrors [M1 and M4 in Fig. 4(a)].

second, the dimension of the limiting aperture (the ocular itself) is not affected by the magnification.

The Keplerian design also lends itself well to simulsion. Tilting mirror $M4$ [in Fig. 4(a)] a few degrees clockwise will shift the magnified image up, as illustrated in Fig. 2(b). An angular displacement upward of T deg can be achieved by tilting the $M4$ mirror ($1/2T$ deg). This provides the wearer with an unobstructed, nonmagnified view of the environment through the carrier lens at the same time as a magnified image (through the telescope) that is translated vertically, enabling an open, wide horizontal FOV, including that of objects seen through the telescope [Fig. 2(b)]. The magnified image could be shifted in other directions, but shifting the magnified image above the unmagnified view is preferable, because the magnified image occupies an area of the visual field that is less likely to include obstacles or other mobility-relevant objects. The in-the-lens telescope design facilitates simulsion, in part, because there is no opaque frame or mounting structure to block the unmagnified view.

The optical elements that act as objective and ocular lenses can be conventional meniscus lenses attached to the carrier lens, as shown in Figs. 3 and 4. However, those lenses could be replaced with curved mirrors, Fresnel lenses, diffractive lenses, or holographic elements. These other elements have a durability advantage, as they can be embedded within the carrier lens. Curved mirrors also offer several other important benefits: mirrors are free of chromatic aberration; they yield more optical power with the same curvature when compared with plano-convex lenses (thus reducing the dimension requirements for the carrier lens); and the distance between mirrors needed to create an afocal optical system does not depend on the refractive index of the carrier lens, but only on their focal lengths.

2.3 Keplerian Prototype with Laminated Lenses

In a first prototype, we implemented the generic design described in Sec. 2.2 (shown in Fig. 4). The lower image-erecting mirrors were made by cutting an ophthalmic lens blank, and the periscopic mirrors were created using small prisms. All mirroring was achieved in this design through total internal reflection, as shown in Fig. 5.



Fig. 6 An image photographed through the first prototype shown in Fig. 5. The magnified image of the CVS sign is shown above and to the right of the nonmagnified view of the sign obtained through the carrier lens, illustrating spatial multiplexing by shifting. The shift was obtained by tilting the whole lens assembly relative to the camera, which resulted in a blurred magnified image.

Figure 6 is an image photographed through the prototype shown in Fig. 5. The magnified image of the “CVS” sign is seen at the same time as the nonmagnified view of the sign obtained through the carrier lens. This illustrates the possibility of spatial multiplexing by shifting. In this case, the image shift was achieved by tilting the whole lens assembly relative to the camera. This tilt resulted in blurring of the magnified image due to induced astigmatism. A much better quality image of the “CVS” sign was obtained in a direct (nontilted) view through the telescope (not shown).

2.4 Keplerian Design with Curved Mirrors

Figure 7 shows top, front, and side views of a Keplerian design in-the-lens telescope using curved mirrors (*M1* and *M4*) to achieve both the optical power and periscopic/erecting functions. Using spherical mirrors in this design with a 45-deg tilt is impractical, as the astigmatic effect will make the telescope useless. It is possible, however, to use off-axis parabolic mirrors. Such mirrors can provide a sharp magnified image; however, as we show in Secs. 2.5 and 3.1, the off-axis

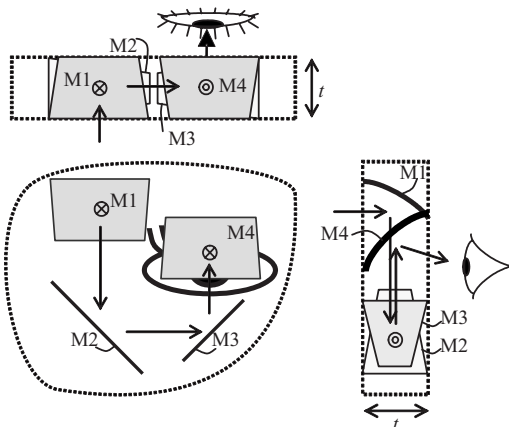

Fig. 7 Top, front, and side view schematics of the in-the-lens telescope using only mirrors embedded in the carrier lens. Curved off-axis parabolic mirrors (*M1* and *M4*) for power and flat mirrors (*M2* and *M3*) for the second image inversion.



Fig. 8 An astronomical Keplerian prototype telescope constructed from two 90-deg off-axis parabolic mirrors.

imaging results in significant anisotropic spatial distortion. This distortion might be disturbing (mostly during image motion) even if it does not affect functionality.

2.5 Keplerian Prototype with Off-Axis Parabolic Mirrors

Second-generation prototypes of Keplerian telescopes were built using off-axis parabolic mirrors. The first prototype used 30-deg off-axis metal mirrors (Edmund Optics, Barrington, New Jersey) that we had on hand. It validated the approach of using off-axis parabolic mirrors and provided satisfactory image quality as judged by observation. The system exhibited a moderate level of distortion. The distortion was hardly noticeable on a static image of a building that provided a good grid structure. However, the distortion became noticeable as the telescope was moved. A second prototype was constructed using 90-deg off-axis mirrors (NT47-100: diameter 25.4 mm and effective focal length (EFL) 101.6 mm; and NT47-098: diameter 25.4 mm and EFL 50.8 mm, also from Edmund Optics), resulting in a 2× Keplerian telescope (Fig. 8). This prototype did not include the two flat erecting mirrors; therefore it provided an inverted image (see Fig. 9).

2.6 Keplerian Design with Beamsplitters

An alternative design for a fully embedded Keplerian in-the-lens telescope without the distortion uses two assemblies of beamsplitters in combination with spherical concave mirrors to obtain the optical power and the periscopic mirror effects, as shown in Fig. 10. This approach implements a magnifying element similar to that used in the in-the-lens electronic display developed by MicroOptical Engineering Corporation

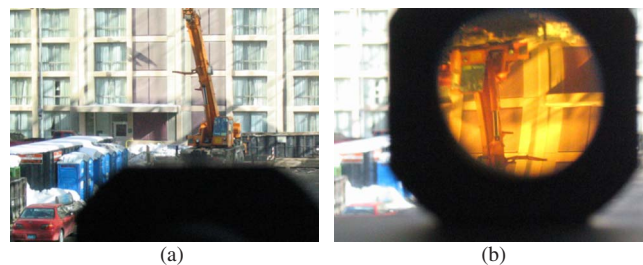

Fig. 9 The view through the 2× astronomical Keplerian telescope created with two 90-deg off-axis parabolic mirrors. (a) A view of a building across the street. (b) The view of the same building through the telescope, showing a clear magnified inverted image of the crane and significant distortion in one meridian. The color of the image is a result of the gold coating of the mirrors.

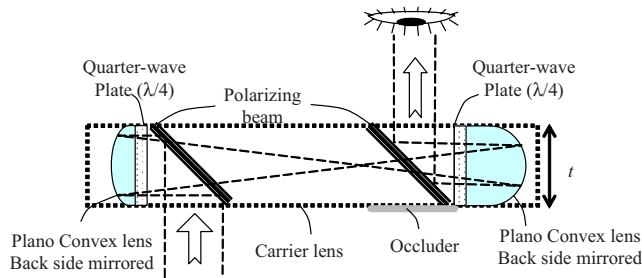

Fig. 10 A schematic of a Keplerian (astronomical-reversing) in-the-lens telescope using spherical mirrors, polarizing beamsplitters, and quarter-wave plates.

(Westwood, Massachusetts).³⁹ Light entering the carrier lens at the objective window on the left (Fig. 10) is reflected by the first beamsplitter toward the concave mirror to the left (the objective). Following reflection and convergence at the concave mirror, the light passes to the right through the beamsplitter traveling through the carrier lens, forming an intermediate image plane, and proceeding through the second beamsplitter. It reflects off the second spherical concave mirror (the ocular), and is then reflected by the second beamsplitter into the wearer's eye. This arrangement provides a Keplerian (astronomical, reversing) telescope with significant light loss due to the four passes through the beamsplitters. Four such passes result in a loss of 15/16 (94%) of the entering light.

The light loss can be substantially recovered using polarizing beamsplitters and quarter-wave plates (Fig. 10). The first polarizing beamsplitter that reflects only the S-component results in a 50% loss of light. Following reflection in the objective curved mirror and passing twice through the quarter-wave plate, the reflected light will be polarized appropriately to pass almost unaffected through the polarizing beamsplitter. Assuming there is no change in the polarization state of the light as it travels through the carrier lens, it will pass through the second polarizing beamsplitter with minimal loss. Because of two passes through the quarter-wave plate associated with the second mirror, the light will then be reflected at the second beamsplitter. Thus the total light loss can be limited to 50% in an ideal situation. In practice, both reflection and transmission factors can be only about 80% efficient for the selected polarization state. After two reflections and two transmissions through the beamsplitters, a total loss of light would be about 80% from natural light (0.5×0.8^4). Because the eye's sensitivity is logarithmic, 80% loss of brightness should not significantly impact the functionality of the telescope. The light loss can be compensated for, in part, by increasing the width of the objective lens, providing more light collection, as discussed later.

An additional advantage of the beamsplitter design is that the semitransparent beamsplitter is less visible than a regular mirror, which improves the cosmetic appearance of the device. However, this advantage holds only for the objective; the ocular beamsplitter requires an opaque backing to improve the contrast of the image for the wearer. The reduced visibility of the objective means that it can be made larger and brought closer to the ocular, as it will not block the view through the carrier lens. Using a semitransparent mirror also removes the

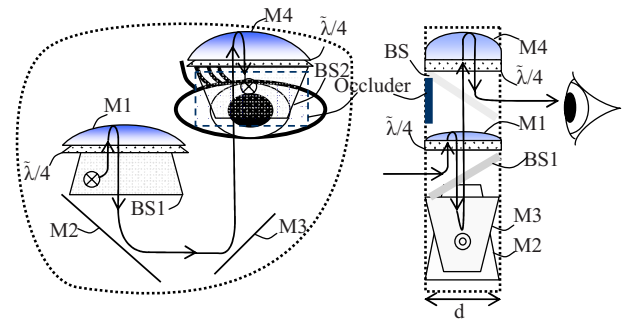

Fig. 11 Front and side views of the Keplerian (terrestrial-erecting) in-the-lens telescope design using polarizing beamsplitters and spherical mirrors. Quarter-wave plates ($\lambda/4$) are inserted between the beamsplitters and the mirrors. Half of the light is lost at the first reflection in the beamsplitter, but ideally the quarter-wave plate assures that the light reflected from the mirror is polarized to pass unaffected through the beamsplitter. This light polarization causes no light to be lost through both passes in the second beamsplitter. The occluder in front of the ocular beamsplitter is required to block the see-through view and increase the contrast of the magnified image. The ocular and objective are shown at different vertical positions on the carrier only to facilitate the side view illustration; they can be placed at the same height if needed.

constraint that the objective mirror be placed farther from the line of sight of the wearer, thus allowing the carrier lens to be made smaller. A smaller carrier lens reduces system weight, and is also currently more fashionable. The ability to see through the objective area also allows for a wider objective, which can in part compensate for the light loss at the first beamsplitter.

The opaque occluder for the ocular beamsplitter can be achieved by providing a polarizer across the whole front of the lens. The polarizer will turn opaque for the ocular lens but will remain transparent for the objective lens. The light attenuation through the polarizer across the whole carrier lens may provide a glare control that will increase both the visual comfort of the wearer and the relative brightness of the view through the telescope (as compared to the view through the carrier lens).

A challenge to the beamsplitter-based approach, however, is that any birefringence in the carrier lens material can rotate the polarization of the light. The rotated light will then be partially reflected, rather than transmitted, in the first pass through the second beamsplitter, and will reduce the light efficiency of the system. Thus the carrier lens has to be as free as possible from birefringence effects.

To convert the astronomical Keplerian telescope design using beamsplitters (Fig. 10) to a terrestrial setup requires an erecting system. Figure 11 illustrates one such terrestrial design constructed by rotating the two assemblies around axes perpendicular to the carrier lens, ultimately placing the spherical mirrors above the beamsplitters. This design, similar to the basic Keplerian design (Fig. 4), uses the beamsplitters as part of the image erecting system. Importantly, this design preserves the property that the width of the fields and the size of the objective are not limited by the thickness of the carrier lens.



Fig. 12 A prototype implementing an astronomical Keplerian telescope using polarizing beamsplitters and spherical mirrors. The objective assembly (top) is composed from the magnifying element of a MicroOptical display system, which includes a polarizing beamsplitter, a quarter-wave plate, and a spherical mirror (top). The ocular assembly (below) is constructed from a polarizing cube beamsplitter, a quarter-wave plate, and a conventional plano-convex lens that was silvered on the convex surface. A dark occluder is visible behind the image of the ocular spherical mirror.

2.7 Keplerian Prototype with Polarizing Beamsplitters

The third prototype implemented the totally embedded design with polarizing beamsplitters (Fig. 12). It included as objective elements the magnifier from the MicroOpticalsee-through head-mounted display EyeGlass (after removing the display).³⁹ This element included a broadband polarizing beamsplitter, a quarter-wave plate (centered in the visible spectrum), and the spherical mirror. All the elements were embedded in an 8-mm-thick carrier lens. For the ocular elements, we used off-the-shelf components that were available on hand: a 1-in polarizing cube, a quarter-wave plate, a mirrored plano-convex lens with rectangular shape (8×15 mm), and an occluder to increase contrast. The magnification obtained was $2.9\times$, as the ratio of the mirrors' radii.

The folding/erecting flat mirrors described in the terrestrial version were not included, so the final image was inverted (Fig. 13). The final image was colored, since the off-the-shelf beamsplitter that we used was tuned for infrared applications

instead of visible broadband. In Fig. 13(c), we illustrate simulvision obtained by simply tilting the ocular beamsplitter.

3 Detailed Optical Designs

ZEMAX software (ZEMAX Development Corporation, Bellevue, Washington) was used in simulation and ray tracing using actual components and specific dimensions. Reported computational results used the geometrical image analysis tool to evaluate FOV using various designs, and also allowed us to assess the image quality in terms of distortion and point spread function (PSF). Our prototypes were selected for construction based on the analysis performed in ZEMAX.

3.1 Keplerian Design with Off-Axis Parabolic Mirrors

As described generically in Sec. 2.5, we used 90-deg off-axis parabolic mirrors with radii of 60 and 20 mm for the objective and ocular, respectively, providing an effective magnification of $3\times$. The “shape form” of the selected mirrors was 20 mm horizontally and 5 mm vertically (for a 5-mm-thick carrier lens). Mirrors were embedded in a flat carrier lens of BK7 glass [Fig. 14(a)]. This design resulted in a convenient eye relief of 15 mm from the back surface of the carrier lens.

Image quality, in terms of the PSF or modulation transfer function (MTF), was satisfactory in the central field, but degraded rapidly with increasing eccentricity [Fig. 14(b)]. Due to the rapid degradation of the image in the vertical direction, increasing the vertical dimension of the mirrors provided no effective increase in the vertical field. The main effect illustrated by this analysis was the anisotropic distortion due to the differences in curvature that mirrors present to tilted rays [Fig. 14(b)]. The distortion was confirmed in a prototype of this design, which enabled us to experience the disturbing visual effect of the distortion (as described in Sec. 2.5).

3.2 Keplerian Design with Beamsplitters

This is the design described generically in Sec. 2.6. Using a biplanar carrier lens of 8 mm thickness, the following design achieved a 1:2 format in the image field with an entrance pupil of 16 mm horizontally and 8 mm vertically. As described before, two polarizing beamsplitters, in combination with thin quarter-wave phase plates, allowed the use of on-axis spherical mirrors. These mirrors were made by mirror-coating the curved surfaces of a pair of conventional plano-convex lenses from Edmund Optics catalog (Edmund Optics Incorporated, Barrington, New Jersey), NT45-153 and NT45-360 models, with 29.21 and 38.76 mm of radius, respectively. The 3-D layout of this design, with the described lens configuration, is shown in Fig. 15(a). The magnification obtained was $3.33\times$ with an eye relief of 10 mm from the last surface. Figure 15(b) shows the final retinal image of two square 5×5 grid objects, subtending 5 and 20 deg, respectively; the larger grid illustrates the vignetting of the outer edges of the field. Since on-axis spherical mirrors were used, the image distortion problem was satisfactorily solved. In this design, the vertical field extent is limited by the lens thickness and the mirror size and not by the image quality.

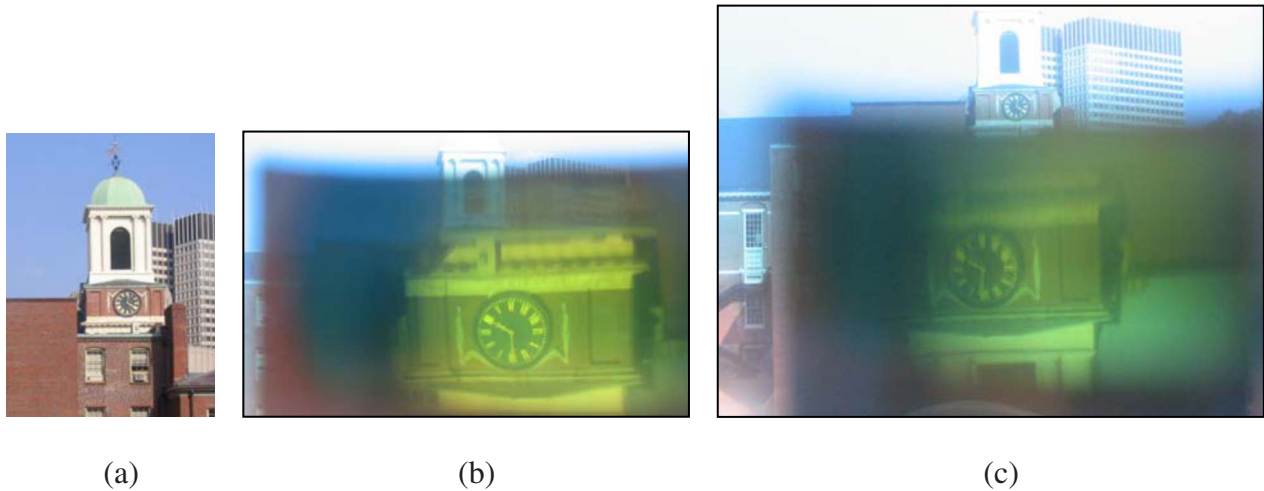

Fig. 13 View through the astronomical Keplerian prototype with polarizing beamsplitters shown in Fig. 12. (a) The natural view of the clock tower. (b) A magnified view ($2.9\times$) as photographed through the prototype (note the reversed clock). (c) Vision multiplexing achieved by tilting the beamsplitter cube permitting both views of the clock, the natural and the magnified, to be seen simultaneously. The magnified image is colored because the polarizing cube beamsplitter was designed for near infrared.

4 Additional Considerations

4.1 Field of View

The ocular lens (mirror) of the in-the-lens telescope is likely to be rectangular in shape. In the horizontal dimension, the only limitations on the lens size are: the dimension of the lens itself, the spectacle frame, and the value chosen for the telescope length L . The vertical extent of the lenses, however, is limited by the carrier lens thickness t . The embedded ocular mirror ($M4$ in Fig. 7) would be the field stop, and we can approximate the restriction to its vertical size as being less than or equal to t . A reasonable range of carrier lens thickness would be 5 to 10 mm. For example, a thickness of 10 mm with a 10-mm eye relief allows a vertical visual field up to 53 deg in the image space (on the retina), which translates to approximately 18 deg in object space, 50% wider than most

current bioptic telescopes. The horizontal FOV (which is less restricted) may be as much as twice as wide as the vertical dimension. The horizontal extent of the FOV is usually considered more important for navigation and reading, so even thinner carrier lenses would be acceptable.

4.2 Light Economy

The dimensions chosen for the carrier lens (e.g., thickness) limit the dimensions of the objective lens (mirror), which in turn also determine the size of the exit pupil. The exit pupil size is important in determining the light efficiency of the telescope. When the exit pupil completely covers the eye's pupil, the light efficiency is maximal at 100%. As stated before, the carrier lens thickness limits the vertical extent of the objective, and thus, the exit pupil. However, the horizontal

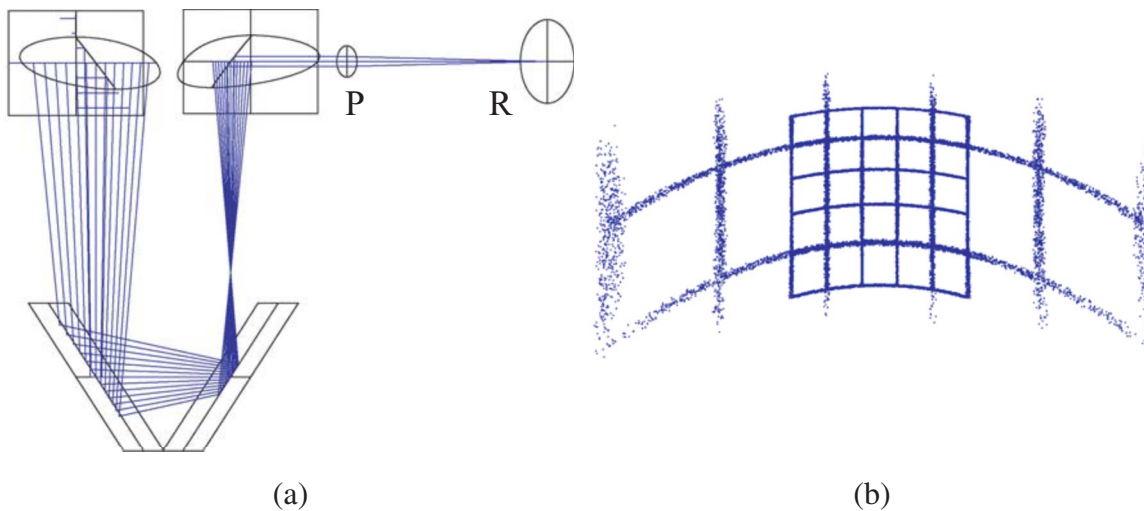

Fig. 14 (a) 3-D layout and ray tracing of the off-axis parabolic mirror design showing eye pupil (P) and retina (R). Rectangles represent effective areas for the first and second surfaces of the carrier lens. (b) Image from two square 5×5 grid objects, subtending 5 and 15 deg, respectively. Notice the similarity of the distortion to that shown in Fig. 9.

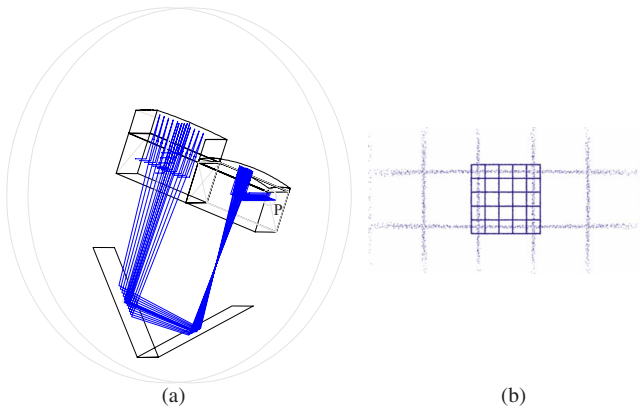

Fig. 15 (a) 3-D layout and ray tracing of the polarizing beamsplitter design showing eye pupil (P) and 8-mm-thick carrier lens. (b) Image from two square 5×5 grid objects, subtending 5 and 20 deg, respectively. Notice the reduction of distortion compared to the parabolic mirrors design (Fig. 14).

extent can be much larger and is not constrained by the thickness, resulting in a wide rectangular-shaped objective. The exit pupil, the image of the objective aperture through the ocular, will also have the dimensions of the objective divided by the magnification. For example, an entrance pupil of 16 × 8 mm (carrier lens 8 mm thick), with a magnification of 3.3×, yields an exit pupil of 4.8 × 2.4 mm. These dimensions may limit the amount of light entering the eye due to pupil coupling.⁴⁰ For the same example, assuming an eye pupil of 3 mm, the maximum light efficiency is 90% [Fig. 16(a)] but is reduced to 80% with a square 8 × 8-mm entrance pupil [Fig. 16(c)]. With an eye pupil of 4 mm, the light efficiency with the rectangle entrance pupil is reduced to 72% [Fig. 16(b)], but with the square pupil it will fall further to 58% [Fig. 16(d)]. Thus extending the horizontal dimension of the

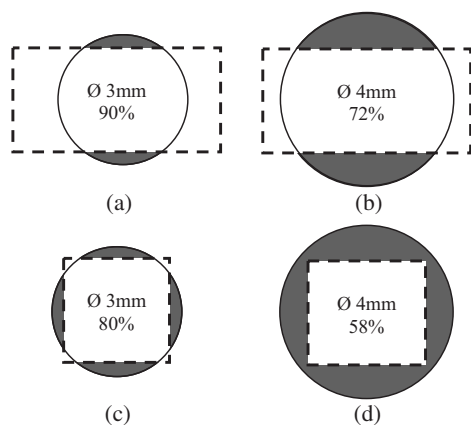

Fig. 16 Improvements in light efficiency of the effective pupil of the eye-telescope system resulting from extending the exit pupil horizontally. Dashed squares and rectangles represent the exit pupil sizes for two different eye pupil diameters (3 and 4 mm, respectively) using both a square and horizontally extended entrance pupils. The light gain (or actual loss) is equal to the percentage area of the eye pupil covered by the exit pupil, as shown in the diagrams. The benefit of a rectangular objective in terms of light efficiency is shown to increase with increased eye pupil diameter.

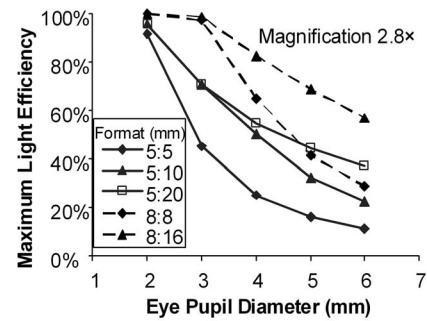

Fig. 17 The influence of the carrier lens thickness, entrance pupil format factor, and eye’s pupil diameter on the light loss due to exit pupil coupling in a Keplerian telescope of magnification 2.8×. For the 5-mm lens thickness, expanding the entrance pupil horizontally to 10 mm substantially improves light efficiency for all pupil diameters. Further expansion results in modest effect and only for large eye pupils. For the 8-mm lens, doubling the horizontal dimension is beneficial for all suboptimal pupil sizes, but further increase of the horizontal dimension is of little value (not shown).

objective (which is possible) would improve the light collection of the telescope when the pupil is enlarged (e.g., in dim light conditions), compared with a square objective.

The overlap between the exit pupil and the eye’s pupil may also be reduced by scanning eye movements that take the pupil away from the center of the exit pupil. Since most eye movements, especially with a wider horizontal FOV, will be in a lateral direction, the wider horizontal extent of the exit pupil will protect the light efficiency during such eye scanning. Thus a wider objective is desirable, even if the wider FOV is not necessary.

We computed the effects of the carrier lens thickness on the maximal possible light efficiency due to the exit pupil coupling. Figure 17 shows the results for an eye centered on the exit pupil in a telescope of magnification 2.8× as a function of eye pupil diameters, for two levels of carrier lens thickness (5 and 8 mm, respectively), and for different format factors representing the ratio of vertical to horizontal dimensions of the entrance pupil. Older people would present small pupil diameters (about 3 mm in diameter), while larger pupils would be expected for young wearers under dim light conditions. As can be seen, expanding the horizontal by a factor of 2 substantially increases the maximum light efficiency for both levels of lens thickness. Expanding the entrance pupil further horizontally results in minimal additional benefit [expanding the 8-mm vertical entrance pupil to 8:24 results in no additional benefit over the 8:16 case (not shown)].

4.3 Refractive Correction

As eyewear, the in-the-lens telescope must provide refractive correction for the wearer both through the telescope and through the carrier lens. All our diagrams have illustrated the carrier lens as a flat lens on both sides and thus could be used only by individuals without any refractive error (emmetropes). A refractive correcting lens could be laminated to the back surface of the lens or be ground into that surface. Such a correction will apply equally to the telescope and the carrier. A standard ophthalmic lens blank is usually provided as a meniscus lens with a front convex surface (base curve).



Fig. 18 Simulation of the expected appearance of the in-the-lens telescope.

The positive front base curve is needed for better cosmetics and for improved optical performance.⁴¹ The refractive correction is typically applied using widely available equipment to grind the back surface of the semifinished lens blank. The same approach can be easily applied to the in-the-lens telescope. The lens blank for this telescope may be developed with a fairly flat base curve. The telescope optical tube length needs to be slightly modified from the afocal configuration to result in a vergence at the second beamsplitter, which is identical to that created by the base curve at the back surface. With such a blank, the back surface may be ground to the wearer's prescription on the back surface using standard ophthalmic laboratory techniques and equipment. The correction applied to the carrier lens will result in an appropriate correction for the telescope as well. This would make such a lens easily dispensable in every ophthalmic shop. Tilts generated in the objective and the ocular due to the prismatic effect of the carrier lens (Percival's rule) can be compensated by centering the curved surfaces on each beamsplitter, if needed. Alternately, the prismatic effect may be used to support vision multiplexing.

A side effect of using a curved carrier lens is that the magnification is slightly reduced compared with the plano-parallel carrier lens equivalent, using the same curved mirrors. The reason for such an effect can be easily described as an increase of the objective lens power and a reduction of the ocular power due to the curved carrier surfaces. Thus, the magnification as the ratio of both refractive powers is reduced. To quantify the effect, we simulated the same model described in Fig. 15 embedded in three plano carrier lenses with base curve surfaces of 0, +1, and +3 diopters, resulting in angular magnifications of 3.3 \times , 3.2 \times , and 3.0 \times , respectively.

5 Discussion

We have described a novel design for bioptic telescopes. We have proposed and tested a family of possible designs for Galilean and Keplerian bioptic telescopes using either laminated lenses, embedded curved mirrors, or polarizing converging beamsplitters. We have analyzed these designs through computer simulations and prototyped the designs to demonstrate the feasibility of such devices. These analyses provide insight into constraints on magnification, image quality, FOV, distortion, and their utility in vision multiplexing.

Bioptic telescopes are the most efficient visual aid available for distance vision, yet they are commonly rejected by people with low vision due to their appearance. Our approach

addresses this limitation while maintaining visual performance similar to or better than current bioptic telescopes. Although the in-the-lens telescope is not cosmetically invisible, its compactness and internalized components attract less attention than current designs. Figure 18 shows a conceptual simulation of the appearance of the in-the-lens Keplerian telescope.

The proposed in-the-lens telescope can be used to simultaneously view the magnified image and the unmagnified image of the same area. This vision multiplexing feature improves wearer orientation and navigation. The wearer can easily locate an object or determine the relative position of the object. The spectacle lens can include the wearer's correcting prescription. We believe that these features will make this device very desirable and that the ability to incorporate the wearer's prescription using standard ophthalmic procedures will control the cost of the device and will support its wide distribution.

Acknowledgments

Supported in part by NIH grants EY 12890 and EY05957. Vargas-Martín received a travel grant from Fundación Séneca, (Murcia, Spain). We thank Morey Waltuck for help with the construction of the Keplerian design with laminated lenses, and Gang Luo for help with the construction of the off-axis parabolic mirrors prototype.

References

1. G. R. Watson, J. Maino, and W. De L'aune, "Comparison of low-vision reading with spectacle-mounted magnifiers," *J. Rehabil. Res. Dev.* **42**(4), 459–470 (2005).
2. E. Peli and W. P. Siegmund, "Fiber optic reading magnifier for the visually impaired," *J. Opt. Soc. Am. A* **12**(10), 2274–2285 (1995).
3. R. Lund and G. R. Watson, *The CCTV Book: Habilitation and Rehabilitation with Closed Circuit Television Systems*, LUV Reading Series, Synforum ans., Froland, Norway (1997).
4. C. Dickinson, *Low Vision: Principles and Practice*, Butterworth, Oxford (1998).
5. H. A. Greene, R. Beadles and J. Pekar, "Challenges in applying autofocus technology to low vision telescopes," *Optom. Vision Sci.* **69**(1), 25–31 (1992).
6. E. Peli, "Vision multiplexing: an engineering approach to vision rehabilitation device development," *Optom. Vision Sci.* **78**(5), 304–315 (2001).
7. E. Peli and D. Peli, *Driving With Confidence: A Practical Guide to Driving With Low Vision*, World Scientific, Singapore, (2002).
8. A. R. Bowers, D. H. Apfelbaum, and E. Peli, "Bioptic telescopes meet the needs of drivers with moderate visual acuity loss," *Invest. Ophthalmol. Visual Sci.* **46**(1), 66–74 (2005).
9. A. Simon, "Fernbrille," Germany patent 302387 (1917).
10. B. Q. Jones, "Goggles," USA patent 1,610,553 (October 31, 1924).
11. J. Bartschat, "Brillenartige haltevorrichtung für Doppelfernrohre," Germany patent 863,423 (1953).
12. W. Feinbloom, "Driving with bioptic telescopic spectacles," *Am. J. Optom. Physiol. Opt.* **54**(1), 35–42 (1977).
13. T. Harkins and J. H. Maino, "The BITA telescope: a first impression," *J. Am. Optom. Assoc.* **62**(1), 28–31 (1991).
14. A. Nguyen, A.-T. Nguyen, R. P. Hemenger, and D. R. Williams, "Resolution, field of view, and retinal illuminance of miniaturized bioptic telescopes and their clinical significance," *J. Vision Rehab.* **7**, 5–9 (1993).
15. J. P. Szlyk, W. Seiple, D. J. Laderman, R. Kelsch, J. Stelmack, and T. McMahon, "Measuring the effectiveness of bioptic telescopes for persons with central vision loss," *J. Rehabil. Res. Dev.* **37**(1), 101–108 (2000).
16. H. A. Greene and J. Pekar, "Bioptic telescope utilization survey," *J. Rehabil. Res. Dev.* **1**(3), 39–48 (1987).

17. R. T. Jose, L. A. Spitzberg, and C. L. Kuether, "A behind the lens reversed (BTLR) telescope," *J. Vision Rehab.* **3**, 37–46 (1989).
18. L. Spitzberg, R. T. Jose, and C. L. Kuether, "Behind the lens telescope: a new concept in bioptics," *Optom. Vision Sci.* **66**, 616–620 (1989).
19. H. A. Greene, J. Pekar, R. Brilliant, P. B. Freeman, H. T. Lewis, R. Siwoff, C. Paton, D. J. Madden, and R. Westlund, "The ocutech vision enhancing system (VES): utilization and preference study," *J. Am. Optom. Assoc.* **62**(1), 19–27 (1991).
20. D. R. Williams, "The bi-level telemicroscopic apparatus--(BITA)," *Problems Optomet.* **3**(3), 495–503 (1991).
21. W. F. Hoeft, "The microspirial Galilean telescope," *Problems Optomet.* **3**, 490–494 (1991).
22. W. M. Ludlam, "Clinical experience with the contact lens telescope," *Am. J. Optom. Arch. Am. Acad. Optom.* **37**(7), 363–372 (1960).
23. T. R. Willis and V. Portney, "Preliminary evaluation of the Koziol-Peyman teledioptric system for age-related macular degeneration," *European J. Implant Refract. Surg.* **1**, 271–276 (1989).
24. I. L. Bailey, "Critical view of an ocular telephoto system," *CLAO J.* **13**(4), 217–221 (1987).
25. E. Peli, "The optical functional advantages of an intraocular low-vision telescope," *Optom. Vision Sci.* **79**(4), 225–233. (2002).
26. D. Rushton and N. Cox, "A new optical treatment for oscillopsia," *J. Neurol., Neurosurg. Psychiatry* **50**(4), 411–415 (1987).
27. L. Moore, "The contact lens for subnormal visual acuity," *Br. J. Physiol. Opt.* **21**, 203–204 (1964).
28. J. E. Koziol, G. A. Peyman, R. Cionni, J. S. Chou, V. Portney, R. Sun, and D. Trentacost, "Evaluation and implantation of a teledioptric lens system for cataract and age-related macular degeneration," *Ophthalmic Surg.* **25**(10), 675–684 (1994).
29. E. Peli, "Double bifocal telescopic IOL-spectacle device for low vision use," U.S Patent Application 60/310,664 (2001).
30. E. Peli, I. Lipshitz, and G. Dotan, "Implantable miniaturized telescope (IMT) for low vision." *Vision Rehabilitation: Assessment, Intervention and Outcomes*, C. Stuen et al., Eds. 200–203, Swets and Zeitlinger, Lisse (2000).
31. H. L. Hudson, S. S. Lane, J. S. Heier, R. D. Stulting, L. Singerman, P. R. Lichter, P. Sternberg, and D. F. Chang, "Implantable miniature telescope for the treatment of visual acuity loss resulting from end-stage age-related macular degeneration: 1-year results," *Ophthalmology* **113**(11), 1987–2001 (2006).
32. G. Fonda, "Approach magnification is safer than bioptic telescopic spectacles for operating a motor vehicle," *Trans. Pa Acad. Ophthalmol. Otolaryngol.* **35**(2), 137–40 (1982).
33. G. Fonda, "Bioptic telescopic spectacle is a hazard for operating a motor vehicle," *Arch. Ophthalmol. (Chicago)* **101**, 1907–1908 (1983).
34. O. Lippmann, A. L. Corn, and M. C. Lewis, "Bioptic telescopic spectacles and driving performance: a study in Texas," *J. Visual Impair Blind.* **82**(5), 182–187 (1988).
35. BITA, *Bita Reference Manual*, Edwards Optical Corporation, Barrington, NJ (1989).
36. E. Peli and F. Vargas-Martin, "Bioptic telescope system embedded into a spectacle lens," United States Patent 6,775,060 (August 10, 2004).
37. J. Schwiegerling, *Field Guide to Visual and Ophthalmic Optics*, 1st ed., SPIE Field Guides, SPIE Press, Bellingham, WA (2004).
38. W. B. Wolfe, "Nondispersive prisms," in Ed. *The Handbook of Optics*, M. Bass, D. R. Williams, W. I. Wolfe, Eds., pp. 4.1–29 McGraw Hill, NY, (1994).
39. M. B. Spitzer, P. M. Zavracky, J. Crawford, P. Aquilino, and G. Hunter, "Eyewear platforms for miniature displays," in *Digest Tech. Papers SID 01*, Society for Information Display, pp. 258–261, (2001).
40. G. Smith and D. A. Atchison, "Instrument exit pupil size (part VI, section 36.4.2)," in *The Eye and Visual Optics Instruments*, pp. 706–708 Cambridge University Press, Cambridge, UK (1997).
41. D. A. Atchison, "Spectacle lens design: a review," *Appl. Opt.* **31**(19), 3579–3585 (1992).